

Do Not Trust Power Management: Challenges and Hints for Securing Future Trusted Execution Environments

Owen Le Gonidec^{*‡}, Maria Méndez Real^{*}, Guillaume Bouffard[†], Jean-Christophe Prévotet[‡]

^{*}Nantes Université, CNRS, IETR-UMR 6164, F-44000 Nantes

Email: {maria.mendez, owen.legonidec}@univ-nantes.fr

[†]National Cybersecurity Agency of France (ANSSI), Paris, France

Email: guillaume.bouffard@ssi.gouv.fr

[‡]UnivRennes, INSA Rennes, CNRS, IETR-UMR 6164, F-35000 Rennes

Email: jean-christophe.prevotet@insa-rennes.fr

Abstract—Over the past few years, several research groups have introduced innovative hardware designs for Trusted Execution Environments (TEEs), aiming to secure applications against potentially compromised privileged software, including the kernel [1]–[3]. Since 2017 [4], Tang *et al.* introduced a new class of software-enabled hardware attacks, which leverages energy management mechanisms. These attacks aim at bypassing TEE security guarantees and exposing sensitive information like cryptographic keys. They have increased in prevalence over the past few years [5]–[7]. Despite that, current RISC-V TEE architectures have yet to incorporate them into their threat models. Proprietary implementations, such as Arm TrustZone and Intel SGX, embed countermeasures. However, these countermeasures are not viable in the long term and hinder the capabilities of energy management mechanisms.

This article presents the first comprehensive knowledge survey of these attacks, along with an evaluation of literature countermeasures. Our analysis highlights a substantial security gap between assumed threat models and the actual ones, presenting considerable threats in modern systems-on-chip that can undermine even the security guarantees provided by TEEs. We advocate for the enhancement of the next generation of RISC-V TEEs to address these attacks within their threat models, and we believe this study will spur further community efforts in this direction.

Index Terms—Hardware Security, Power Management, Fault Injection Attacks, Side-Channel Attack, Countermeasure

I. INTRODUCTION

TO protect sensitive assets, modern mobile computing systems rely on Trusted Execution Environments (TEEs). TEEs offer a secure runtime execution environment where sensitive applications are executed, co-located with a Rich Environment (RE), which may include Operating System (OS) such as Android or iOS. TEEs isolate the execution of sensitive applications from the rest of the system, *i.e.*, from the rich, and potentially untrusted RE, relying on hardware mechanisms. Such environments are widely used to secure critical applications, both in System on Chips (SoCs) and high-end servers. TEEs aim to protect the system against software attacks where the attacker may have full control over the RE,

including the rich OS. Attacks requiring physical access to the system are not part of the TEEs’ threat model [8]–[10].

However, since the mid-2010s, dozens of articles have demonstrated several methods by which a remote attacker can compromise the main security properties of a TEE, utilizing hardware attacks initiated from software, without requiring physical access to the target [11]. This emerging type of attack relies on manipulating software-accessible interfaces to affect hardware components, rendering them a realistic and dangerous threat. Among these, energy-based attacks are particularly significant. They exploit embedded energy management mechanisms maliciously to compromise the security of the victim system. For instance, they may be employed to extract sensitive assets such as cryptographic keys or to bypass authentication procedures. They enable the injection of timing faults in a fault attack [4], [6], extraction of secret information through a Side-Channel Attack (SCA) [5], [12], [13], and creation of a covert communication channel utilized by a Trojan and a spy [7], [14]. Such attacks have been conducted against widely deployed TEEs, such as ARM TrustZone [4], [5], [14] and Intel Software Guard Extension (SGX) [6], [13], [15]. Despite falling into the category of software-induced attacks, these are still not accounted for in TEE threat models.

Among commercial TEE implementations, Intel SGX is the only one that has implemented a mitigation for energy-based fault attacks. However, it consists of restricting the use of power management mechanisms, thereby greatly limiting the primary objective of energy fine-grain optimization [6]. Arm [16] recommends that vendors of TrustZone-enabled TEEs (*e.g.*, Qualcomm or Samsung) implement a similar mitigation—although to our knowledge, no official vendor document mentions an actual implementation. Again, this mitigation is not sustainable eventually, as it results in power waste and does not address the root cause of energy-based attacks. This initial mitigation proposed is specific to fault attacks and does not address other types of energy-based attacks, notably SCAs [5] and covert attacks, which will be reviewed in this article. Consequently, we assert that existing TEEs are vulnerable to this major threat.

Regarding RISC-V-based systems, these energy-based attacks have still not been considered in recent TEE threat models. Even though several works have introduced innovative hardware TEE implementations leveraging the capabilities of the open ISA RISC-V, they do not offer any protection against energy-based attacks [2], [3], [17], [18].

In this article, we provide the first overview of this new category of hardware energy-based attacks and analyse their capabilities, limitations, and evolution over the past few years. To the best of our knowledge, this is the first work reviewing this emergent category of attacks. Additionally, we give an overview of the initial attempts at countermeasures and demonstrate that there is still much to be done in this field. Finally, through an analysis of countermeasure implementation as part of TEEs, we demonstrate that mitigating this new category of attacks constitutes a promising research field for the future.

The remainder of this article is organized as follows: Section II provides background information on physical attacks, power management mechanisms, and TEE. Subsequently, Section III delves into internal energy-based attacks, detailing their types, methods, results, and limitations. In Section IV, we scrutinize the first published and implemented countermeasures against this type of attack as well as their limitations. We provide an overview of the challenges involved in implementing them in practice. Then, we propose potential approaches for addressing these vulnerabilities. Finally, Section V concludes this article and offers insights into future research directions.

II. BACKGROUND

A. Hardware Attacks

Hardware attacks exploit the electronic behaviour of components executing sensitive or critical applications. In the case of SCA, rather than breaking complex mathematical algorithms such as cryptographic schemes protecting secret data, an attacker analyses side-channel signals generated during the execution of the victim application. Examples include the target device’s electromagnetic emanation, power consumption, or computation time. These signals reveal the target architecture and microarchitecture state, allowing an attacker to deduce the instructions and/or data computed, thereby compromising target confidentiality. Similarly, in Differential Fault Analysis (DFA), an attacker can introduce faults into computation or memory by inducing glitches within the electronic device through external sources, potentially resulting in controlled instruction skipping, such as during an authentication process. In both cases, SCA or DFA, the objective is typically to retrieve secret information.

Traditionally, hardware attacks have required physical access to the hardware device, such as through external sensors or sources of glitches. Consequently, hardware attacks were not always considered in most device threat models. However, a new type of software-induced hardware attack has emerged, allowing an attacker application to perform hardware attacks from within the device. By exploiting microarchitectural components shared by the victim and attacker applications, such

as memory caches, communication interconnections, or more recently, power management components, this powerful new type of attack greatly extends the threat surface.

B. Power Management Mechanisms

Optimal power management has been a crucial part of digital systems design, both in constrained SoCs and high-end servers, enabling energy savings and improved thermal management. Among power management technologies, fine-grained control mechanisms such as Dynamic Voltage and Frequency Scaling (DVFS) have been employed for decades. DVFS involves adjusting the supply voltage and operating frequency, which collectively have a cubic impact on power consumption, depending on the system load, to meet performance targets. In this article, we refer to a combination of operating frequency and supply voltage as an Operating Point (OPP) (referred to as *P-States* in Intel terminology). In a typical DVFS implementation, either the OS or the hardware central processing unit (CPU) requests a frequency adjustment based on a workload estimation. The operating voltage is subsequently adjusted based on a set of vendor-defined OPPs. These sets are defined by manufacturers to ensure device safety and can extend beyond the actual operating limits of the device [19]. Indeed, these limits vary due to factors such as ageing, temperature, and manufacturing uncertainties [4], making it impractical for operators to measure the limits of each device. In addition to OPPs scaling mechanisms, the ability to query power consumption, temperature, and operating frequency is a crucial aspect of power management. First, energy-aware programs benefit from software interfaces that allow them to monitor these metrics. It is also directly used by hardware components, for example to implement turbo frequencies and power capping [20].

Figure 1 provides an overview of the main components utilized in a typical DVFS implementation, both for OPP scaling and sensing. It represents one implementation among

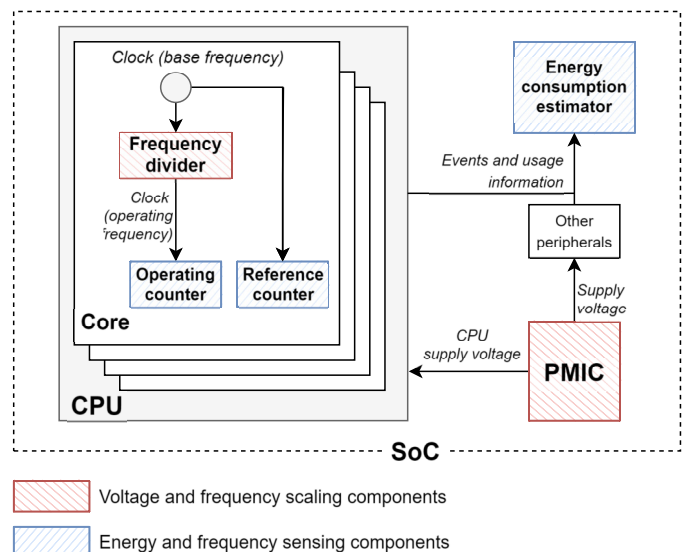

Fig. 1: A typical DVFS implementation, illustrating components used for sensing operating frequency and supply voltage.

many possibilities. Indeed, hardware implementations of such power management mechanisms can vary significantly from vendor to vendor, and they are usually undocumented.

Voltage regulation for all components in a SoC is typically managed by a dedicated component known as the Power Management Integrated Circuit (PMIC). Typically, a single power rail supplies one core cluster, meaning that each core within the cluster operates with the same supply voltage. Conversely, in multicore embedded systems, frequency dividers are internally managed by a core, enabling each processor to have its own clock domain and operate at its own frequency. With the trend toward more aggressive power management mechanisms, per-core voltage domains for supply voltage are becoming more common, as implemented in some recent Intel processors [21]. At the software level, in Linux-based systems, the OS kernel requests frequency changes through modules such as `cpufreq`, either using an automatic governor or manually setting an operating frequency, such as through model-specific registers (MSRs). The supply voltage is adjusted accordingly based on the vendor-defined OPPs.

On x86 processors, energy consumption can be measured from software using the Running Average Power Limit (RAPL) interface. This interface does not rely on physical power sensors, but instead utilizes a modelling approach based on architectural events communicated by peripherals [22]. This is also the case for operating frequency, *e.g.*, the Linux kernel support for Intel processors where frequency is not given by a physical sensor, but estimated instead by differentiating the value of incrementing counters — one incrementing with a reference frequency and the other incrementing in proportion to the actual performance¹ [23]. In embedded devices, the way that clock frequency and power consumption are retrieved is dependent on the SoC hardware design, on which little information is publicly disclosed. Contrary to x86 systems, here energy consumption may be retrieved from physical sensors, *e.g.*, mobile Android devices where the power supply module communicates battery status to privileged software.

The switching time of transistors is inversely proportional to their supply voltage. Therefore, high voltage is required to achieve high operating frequencies; otherwise, timing conditions at the transistor level are not met, resulting in device instability and *clock glitches* [24]. Although supply voltage is typically adjusted based on operating frequency, it is possible to independently adjust them by directly writing in dedicated MSRs. This presents an entry point for internal energy-based fault attacks, which intentionally trigger clock glitches by configuring a high clock frequency and a low supply voltage.

C. Trusted Execution Environments

Some privileged components, such as rich operating systems, have extensive attack surfaces that make them challenging to secure. For example, the Linux kernel comprised over 27 million lines of code in 2020, with nearly two thousand vulnerabilities disclosed [25]. Therefore, these privileged components cannot be relied upon to ensure the security of critical programs. This realization gave rise to the concept

of relying on a minimal set of security-oriented components to form a Trusted Computing Base (TCB). The aim is to keep the TCB as small as possible, providing hardware-assisted mechanisms to isolate critical programs from the main computing environment. Since the late 1990s, separate co-processors known as Trusted Platform Modules (TPMs) have been utilized for this purpose [26]. However, Trusted Platform Modules (TPMs) can only protect a predefined set of functionalities. The necessity to extend this protection to third-party programs on rich, performance-oriented processors led to the development and standardization of TEEs in the early 2010s [27].

A TEE is a secure environment comprising memory, storage, and processing capabilities, isolated from the rest of the system, often referred to as the RE [28]. While a TPM relies on executing security-critical programs on an external, isolated component, in a TEE, both trusted, and untrusted programs run on the same CPU/microcontroller and share the same hardware resources, with access mediated by a dedicated component known as the Security Monitor (SM). The TEE utilizes on-chip hardware mechanisms to isolate and provide integrity and confidentiality to security-critical programs in systems where privileged software, such as kernels and hypervisors in the RE, is untrusted. This includes servers used by stakeholders for data storage and computation outsourcing (cloud computing), where trust in the cloud provider may be lacking. This scenario is a common use case for Intel and AMD TEEs, specifically SGX and SEV. In the embedded market, ARM TrustZone provides hardware support for TEEs to SoC designers. More recently, numerous research papers have leveraged the open RISC-V Instruction Set Architecture (ISA) to propose new hardware designs for TEE support, such as Sanctum [1] or Keystone [2], among others.

TEE implementations vary based on the hardware and software mechanisms they employ to secure trusted applications. A notable distinction between TrustZone and SGX-type TEEs, which encompasses most academic proposals [1], [3], [18], is that in the former, the entire system is divided into two *worlds*. Secure OSs and potentially hypervisors can operate in the trusted world. This approach offers significant flexibility: TEE implementations can prioritize providing extensive functionalities to trusted applications or aim for the smallest possible Trusted Computing Base (TCB), as demonstrated in some studies [8]. However, in the latter approach, untrusted user-level applications, referred to as enclaves, can be individually isolated without needing to trust the kernel and other privileged software. In this protection model, there is a risk of potential malicious enclaves being spawned.

Another essential feature of a TEE is attestation, which ensures that it operates on a physically certified device. This serves various purposes, such as allowing a trusted application to verify that the host system is running an up-to-date version. Additionally, TEEs rely on security primitives like Secure Boot, typically ensured by firmware, which forms part of the TCB of the system. Most academic TEE designs utilize a Secure Monitor (SM) that leverages RISC-V's *Machine Mode* privilege level for this purpose.

¹See: `aperfmpperf.c` in the Linux-kernel source code.

III. INTERNAL ENERGY-BASED ATTACKS

As detailed in Section II-A, physical access to the victim device enables potent power and clock-based attack scenarios, which have been studied and utilized for over two decades. However, lately, several studies have shown that similar attacks can be executed internally using software-accessible energy management mechanisms. This discovery is relatively recent, with such attacks first demonstrated in 2015 for SCAs [29] and in 2017 for fault attacks [4]. Consequently, they pose an emerging threat that may become increasingly dangerous with further discoveries and when combined with other attack vectors.

Most energy-based attacks, including fault attacks and certain SCAs, require access to kernel-restricted registers. Therefore, the attacker must possess kernel-level privileges within the RE. In such scenarios, the attacker targets assets protected against direct access from the rich OS, namely assets within the TEE. While TEEs offer hardware-enforced isolation for trusted assets, energy management mechanisms, such as voltage and frequency regulators, as well as sensors, are shared across power domains, even spanning TEEs and REs. An attacker with full control over the RE can exploit these energy management mechanisms as a side channel to access TEE assets. The methods by which these mechanisms can facilitate fault attacks, SCAs, and covert communication will be described in the following paragraphs.

a) Attacker model: Internal energy-based attacks employ methods similar to physical attacks described in Section II-A: they monitor programs using external power sensors and/or manipulate their execution using external sources of glitches. However, they differ significantly in a crucial aspect: internal attacks utilize software-accessible energy management mechanisms, eliminating the need for the attacker to physically access the device. While traditional physical attacks involve the attacker utilizing off-chip equipment to extract information or manipulate the execution flow, internal attacks are entirely internal and software-driven, thus expanding the threat model to include remote attackers. This significantly increases the attack surface. Moreover, these internal attacks are more cost-effective and carry no risk of damaging the targeted platform, while also posing a serious potential for widespread exploitation [30].

In the following paragraphs, we consider an attacker who has full control over the RE, including the untrusted OS and its drivers. Their objective is to compromise key security properties of the TEE and trusted applications/enclaves, including confidentiality (*e.g.*, stealing cryptographic keys), integrity (*e.g.*, altering processed data), availability (*e.g.*, conducting Denial-of-Service attacks), or authenticity (*e.g.*, loading a self-signed application into the TEE). The attacker is remote; they do not have physical access or proximity to the victim's device but can execute software on the device. Additionally, they may utilize physical equipment on a copy of the device for profiling purposes before conducting the actual attack. For example, they can employ physical sensors to establish a correlation between power consumption and data on their own device during the profiling phase. Subsequently, during the actual

attack, they can exploit the developed model on the victim device through a remote attack utilizing software-accessible power sensors embedded on the chip. This scenario is typical in profiling attacks.

Finally, we assume that the attack program is running on the CPU and does not aim to compromise the security of another component of the SoC. This notably implies that FPGA-to-CPU undervolting fault attacks [31] are outside this review's scope.

b) Fault injection attacks: Internal energy-based fault attacks involve installing a malicious kernel module or driver that accesses the hardware voltage and/or frequency regulators. By independently adjusting the voltage and frequency, the attacker causes the device to operate beyond its specified limits. As described in Section II-A, this results in clock glitches, leading to faults in the processed data or instructions. Typically, an unstable state where faults occur is reached when the supply voltage is low and the frequency is high. The attacker can induce a glitch either by (i) transiently increasing the frequency to an unstable value, referred to as 'overclocking' attacks [4], or by (ii) reducing the power domain's supply voltage while the clock frequency of the victim core is high, known as *undervolting* attacks. Additionally, as discussed in Section II-B, in most DVFSs implementations, each core (or cluster) has its own frequency domain. Attackers exploit this feature to target a victim core (or cluster) without affecting their own attack program.

Software-induced clock glitches represent an emerging threat first demonstrated in [4]. In this study, attackers over-clock the device to induce a transient clock glitch, which they utilize to target Qualcomm Secure Execution Environment (QSEE), a TrustZone-based TEE. Through this method, the authors successfully extract secret AES keys via DFA. Moreover, they demonstrate the loading of a self-signed application into the TEE by disrupting RSA certificate verification. Subsequent research has shown that transient undervolting can achieve similar results [32], and that Intel SGX can also be compromised through energy management mechanisms, by directly manipulating the corresponding MSR [6], [33], [34]. Table I provides an overview of internal energy-based fault attacks published recently, highlighting their distinctive characteristics. The target platforms encompass a range of devices, from smartphone processors (*e.g.*, Qualcomm Krait) to high-end Intel CPUs. Both ARM TrustZone and Intel SGX are shown to be vulnerable to Fault Injection Attack (FIA). These attacks illustrate various use cases, compromising different security properties of the victim device and targeting diverse assets.

These studies present powerful attack scenarios but also reveal numerous limitations. First, achieving precise timing for glitch injection isn't always feasible, depending on how quickly the victim device can switch between different OPP. In [4], attackers could induce a glitch within a 65 000-cycle time window, targeting a specific part of the victim program. However, in Intel architectures targeted in [6], [34], over 500 000 instructions are executed between consecutive OPP change requests, making transient glitch injection impractical. Attackers rely on the fact that certain instructions, such as

TABLE I: Overview of fault attacks exploiting software-accessible energy management mechanisms.

Attack	Target platform (Target TEE)	Glitch injection method	Compromised security properties (assets)
<i>CLKSCREW</i> [4]	Qualcomm Krait (ARM TrustZone)	Overclocking	Confidentiality (extract AES keys from the TEE), Integrity (fault an RSA key during verification), Authenticity (load a self-signed application into TrustZone)
<i>VoltJockey</i> [32], [33]	(i) Qualcomm Krait (ARM TrustZone) (ii) Skylake CPUs (Intel SGX)	Undervolting	Confidentiality (extract AES keys from the TrustZone & SGX), Authenticity (load a self-signed application into TrustZone)
<i>Plundervolt</i> [6]	Skylake CPUs (Intel SGX)	Undervolting	Confidentiality (Extract AES & RSA keys from the TEE), Integrity (Out-of-Bounds memory access)
<i>Voltpwn</i> [34]	Skylake CPUs (Intel SGX)	Undervolting	Integrity (fault SHA-256)
Noubir <i>et al.</i> [35]	Exynos 5422 & Kirin 960	Undervolting	Availability (denial-of-service attack)

multiplications [6] and vector operations [34], are more likely to cause faults, allowing them to target specific parts of a program to some extent. When the victim device does not exhibit such behaviour, supply voltage manipulation can still be used for denial-of-service attacks [35]. Second, not all devices may grant direct access to voltage and frequency regulators. With devices lacking an open-source OS or detailed technical documentation, the corresponding registers remain unknown. The attacks on Intel SGX [6], [33], [34] were made possible by prior research efforts that uncovered the MSR used for voltage control [6]. Third, each device possesses unique properties that can make fault injection via voltage and frequency control challenging, if not impossible. The unstable area triggering faults without device rebooting or freezing may be very narrow on some CPUs. With discrete voltage control precision (e.g., 5 mV steps), reaching this area may prove unattainable, as observed in AMD Zen processors [36].

c) Side-Channel Analysis: In addition to fault injection, recent research efforts have highlighted the emergence of various software-accessible side channels stemming from energy management mechanisms present in today’s systems-on-chip. These side channels can be exploited by attackers seeking to retrieve sensitive assets. Several studies demonstrate different malicious uses of energy management mechanisms targeting various assets. Two primary attack vectors can be exploited for SCAs. The first involves directly reading the device’s data-dependent energy metrics (such as power consumption and clock frequency) using embedded on-chip sensors. The second involves analysing the data-dependent frequency throttling induced by DVFS based on the system load.

The first attack vector has been extensively studied across various devices. In the context of Android smartphones, interfaces providing battery status have been exploited in SCAs for activities such as website fingerprinting [37], location tracking [38], and inferring running apps, including sensitive UI interactions such as user login and password lengths [29]. In [12], Linux’s `cpufreq` module, along with machine learning techniques, is utilized as a low-resolution side-channel for website fingerprinting and input sniffing. On Intel CPUs, the RAPL energy reporting counters were initially identified as a vulnerability by Mantel *et al.* in [15]. More recently, Lipp *et al.* utilized them in the *Platypus* attack [13]. In this latter work, a privileged attacker leverages RAPL counters to extract sensitive information, such as AES secret keys, from an SGX-enclaved application.

The second attack vector is explored in [5], [39]–[41], where the attacker analyses the behaviour of frequency throttling automatically induced by DVFS to maintain a balance between power, frequency, and temperature. These frequency adjustments are shown to be both instruction and data-dependent [39]. An attacker can trigger them forcefully by subjecting the processor to heavy workloads. Moreover, a privileged user can manipulate the power budget threshold at which throttling occurs, facilitating the exploitation of the attack. This methodology has been employed to compromise AES encryption within an SGX enclave [39]. This vulnerability also extends to ARM SoCs, as demonstrated in [40], potentially making it exploitable against TrustZone as well. It is noteworthy that program execution time is directly proportional to clock frequency. Therefore, in attacks where clock frequency serves as the side-channel, attackers can measure the execution time of a dummy program instead of directly accessing frequency metrics, as demonstrated in [5]. This renders frequency throttling attacks difficult to detect and prevent.

Finally, in [42], Kogler *et al.* show that these software-based power SCAs can reveal any arbitrary value in a shared memory component, such as caches. They observe that power consumption subtly varies when an attacker-controlled value is replaced by a victim program’s value. This power consumption variation depends on the Hamming distance between the two values. Therefore, by using two inverted attacker values and differentiating the impact of their eviction on power consumption, they amplify this subtle leakage signal. With this method, an attacker can leak single-bit differences in the victim data, at the maximum rate of 4.82bit/h on the tested CPU (*Intel Core i7-8700K*). This attack is CPU-agnostic, and can be used with either direct measurement or frequency throttling to monitor power consumption.

Table II provides an overview of the software SCAs based on energy management mechanisms outlined in this section. It is evident that despite relying on low-resolution measurements, some attacks can still infer sensitive information.

d) Covert communication: Covert communication is a type of attack similar to SCAs in that it exploits side channels not intended for communication. However, unlike SCAs where a victim program inadvertently discloses secret information, covert communication employs side channels to clandestinely transfer data between a Trojan and a monitoring program. Thus, covert channel attacks utilizing energy management

TABLE II: Overview of Side-Channel Attacks exploiting software-accessible energy management mechanisms. The resolution column defines the minimum time between 2 consecutive measurements.

Attack	Target Platform	Attack Vector	Resolution	Compromised assets
<i>PowerSpy</i> [38]	Android smartphones	Unprivileged reading of battery level	100 ms	Geo-localisation.
Yan <i>et al.</i> [29]	Android smartphones	Unprivileged reading of battery level	175 ms	Running applications, password lengths guessing.
Qin and Yue [37]	Android smartphones	Unprivileged reading of battery level after an offline analysis with a physical probe	1 ms	Website fingerprints.
<i>DF-SCA</i> [12]	Linux-based systems (x86 and ARM)	Unprivileged use of the <code>cpufreq</code> module	10 ms	Website fingerprints, keystrokes.
Mantel <i>et al.</i> [15]	Intel CPUs	Unprivileged access to the RAPL energy counters	1 ms	RSA keys.
<i>Platypus</i> [13]	Intel CPUs	Privileged access to the RAPL energy counters	50 μ s	AES keys from an SGX-enclaved program, KASLR addresses.
Liu <i>et al.</i> [39]	x86 CPUs	Manipulation and analysis of the frequency throttling mechanism (privileged attacker)	—	AES keys from an SGX-enclaved program.
<i>Hertzbleed</i> [5], [41]	x86 CPUs, ARM SoCs and GPUs	Analysis of the timing differences induced by the throttling mechanism (privileged or unprivileged attacker)	—	Cryptographic keys, break KASLR addresses, pixel sniffing, website history.
<i>Collide+Power</i> [42]	Any	Analysis of the power variation during replacement of attacker-controlled data by victim data, using direct measurement or frequency throttling.	—	Any value in a co-located memory (e.g. caches).

mechanisms closely resemble the SCAs discussed in the previous section. Several studies have demonstrated that frequency and power management mechanisms can serve as covert communication channels between a Trojan and a monitoring program, simply by modulating frequency, voltage, or both [7], [14], [43], [44] to encode information.

In these attacks, a program manipulates the device or CPU core voltage and frequency via DVFS, subjecting it to specific workloads, similar to a side-channel attack using frequency throttling. This method can establish covert channels between programs executing within the TEE and those on the RE, such as from a secure CPU core to a non-secure one, or to components outside the SoC like an FPGA [14], provided voltage or frequency regulators are accessible. Even when each core has its frequency/power controller, covert channels can arise from a shared global power controller, as demonstrated in [45].

The throughput of these covert channels varies significantly, ranging from a few bits per second [44] to several megabytes per second [14], primarily depending on the processor and the responsiveness of its frequency changes. Once information is encoded into a covert channel by the Trojan, the monitoring program can detect it directly using software-accessible embedded sensors. However, similar to SCAs, the monitoring program may not necessarily require direct access to frequency registers; monitoring program execution time is an equivalent approach [45], [46].

Although existing research typically adopts a device-agnostic approach, tailoring the attack method to the specific power management mechanisms of the targeted device can yield better results. For example, in [47], Kalmbach *et al.* develop a covert channel designed specifically for Intel’s *Turbo Boost 2* power management technology, which exhibits greater resilience to background noise compared to previous approaches.

IV. DISCUSSION AND COUNTERMEASURES

As observed in Section III, internal energy-based attacks, encompassing fault attacks, SCAs, and covert communication, are not only potent but also cost-effective, posing a substantial threat to all commercial TEE designs.

Despite the multiple demonstrations of these emerging attacks lately, academic RISC-V-based TEE technologies have yet to incorporate protection against them. This is either because such vulnerabilities are perceived as hardware flaws [1], [18] or because their mitigation is believed to be unrelated to TEE protection mechanisms [2], [3]. However, internal energy-based attacks do not exploit flaws in a single hardware block that can be remedied by strengthening its design. Instead, they capitalize on a fundamental vulnerability in the TEE protection model: hardware regulators, accessible by the RE without protection, inherently serve as a side-channel. This side-channel is particularly potent, as it yields results comparable to those of energy and clock-based physical attacks, which are well-recognized and considered significant threats. However, internal energy-based attacks cannot be classified in the same category as traditional physical attacks in terms of the threat model. This is primarily because they do not utilize off-chip equipment but rather leverage equipment already embedded in the hardware device, thus circumventing their primary objective of energy optimization. When no countermeasure is in place, any attacker with kernel-level privileges in the untrusted world—assumed in most TEEs’ adversary models—can execute this type of attack against an application running within the trusted world. Consequently, addressing this vulnerability at its root necessitates designing TEE software and hardware mechanisms to either eliminate or render this side-channel unusable for potential attackers.

Thus, we advocate for the inclusion of mitigation measures against internal energy-based attacks in next-generation TEEs. Such countermeasures do exist. First, certain widely used TEE

TABLE III: Overview of existing countermeasures against energy-based attacks.

Countermeasure	Countered attack type	Implementation status	Main advantages	Main shortcomings
Restrict the RE's access to hardware regulators	Fault attacks	Implemented in Intel SGX [6], recommended by ARM [16]	Simple implementation, implies no overhead	Hinders the capabilities of DVFS, does not address the root cause of the vulnerability
Enforce operating limits with a hardware coprocessor	Fault attacks	Proof-of-Concept (PoC) presented in [19]	Does not restrict the use of DVFS, hardware-level implementation	Area, latency and power consumption overhead (resp. 0.09 mm ² , 1.11 μ s, 10.5 mW)
Separate hardware regulators across security boundaries	Fault attacks	Hypothetical countermeasure formulated in [4], [6], [32]	Does not restrict the use of DVFS, hardware-level implementation	Costly and challenging implementation, area overhead, increase in the TCB's size
Harden trusted programs against faults	Fault attacks	PoC presented in [48], other solutions studied in [41], [49]	Does not restrict the use of DVFS, no hardware modification required	Significant (dozens %) performance overhead for trusted apps
Scramble software-accessible power traces	SCAs (direct reading)	Implemented for Intel SGX [50]	Simple implementation, does not affect other hardware components which need energy reporting	Reduces the accuracy of energy reports (~5-10%)
Prevent the attacker from manually setting an energy budget	SCAs (frequency throttling)	Hypothetical countermeasure formulated in [39]	Makes frequency throttling attacks less practical	Restricts the use of power clamping, doesn't fully prevent frequency throttling attacks

implementations (such as Intel SGX and ARM TrustZone) embed mitigations against the FIA and some SCAs outlined in section III, although they greatly hinder the use of power management mechanisms. Second, several studies have proposed proof-of-concepts countermeasures against energy-based fault attacks [19], [48], [51]. Finally, some well-established methods traditionally employed to counter hardware attacks are also applicable to internal energy-based attacks, given the similarity in their methodologies. All of these avenues offer potential inspiration for next-generation TEE designs to incorporate their own countermeasures. In this section, we first provide an overview of existing mitigation measures against energy-based fault and side-channel attacks, analysing the main advantages and shortcomings of each strategy. We highlight the challenges associated with implementing these countermeasures in real-world hardware TEE. Table III summarizes said countermeasures, and gives their main advantages and shortcomings. We describe them further in this section.

A. Fault attacks countermeasures

1) Forbid the rich OS to access hardware regulators:

To execute a fault attack as described in Section III, the attacker loads a malicious kernel module that directly accesses hardware regulators. Therefore, preventing direct access to these regulators by the rich OS disarms the attacker and effectively prevents DVFS fault attacks. This countermeasure is recommended by manufacturers for TEE implementations that have been targeted in this manner [6], [16]. Regarding "CLKScrew"-like attacks [4], ARM recommends prohibiting the kernel from having "direct and independent control of clock and voltage" and suggests performing regular checks on the requested OPP using a trusted entity such as firmware [16]. However, to our knowledge, no published documents indicate that vendors (e.g., Qualcomm, Samsung, etc.) have implemented this countermeasure in their TrustZone-enabled TEE. Furthermore, in response to undervolting attacks on SGX [6],

Intel disabled access to the voltage control MSR when SGX is enabled through a BIOS update. This update is also included in the TCB attestation that an enclave can request to verify the effectiveness of the update.

This countermeasure could be applied to proof-of-concept RISC-V-based TEE technologies by allocating the M-mode SM for direct access to hardware regulators. If the stability boundaries of the voltage and frequency space are known — which is not trivial, as we discuss in the following paragraph — then the SM can serve as a delegate actor for managing OPP change requests initiated by less privileged software. It would verify that the requested OPP is safe for the system. Alternatively, the system could employ a governor based on system load or scheduler, akin to a Linux-based OS, which can be implemented in two primary ways. Firstly, workload measurements could be performed using either the SM directly or a trusted enclave with exclusive access to associated performance counters. Secondly, a kernel module could be utilized to provide these measurements along with local attestation to ensure its integrity. The overhead associated with this communication remains to be determined. Consequently, implementing this countermeasure may not be straightforward and necessitates well-informed design decisions.

Moreover, we assert that these solutions are not sustainable in the long term as they run counter to the primary objective of power optimization techniques. Indeed, this category of solutions limits power management options to vendor-prescribed OPPs, which may diverge significantly from a device's actual operating limits [19]. It also precludes the ability to adjust them dynamically for precise control over the device's power consumption. Consequently, we can infer that this type of solution has two main drawbacks. Firstly, it impedes the utilization of DVFS to its fullest extent for enhancing performance, minimizing energy consumption, and optimizing temperature, which is particularly crucial in resource-constrained embedded devices, as well as in standard computers and servers where effective power and temperature management are vital. Sec-

ondly, it fails to address the underlying vulnerability, as there are likely additional undocumented methods to manipulate voltage and frequency from the kernel [6].

2) *Enforce the operating limits*: Fault attacks exploiting power management mechanisms rely on glitches occurring when the processor operates beyond its specified operating limits. Therefore, enforcing these limits would render such attacks impractical. However, implementing this in reality may pose challenges. Firstly, determining the actual operating limits of a device is only feasible after a post-manufacturing testing phase, making it practically difficult to enforce hardware-enforced hard limits [4]. Secondly, various factors contribute to the fact that even two similar devices manufactured on the same wafer may have different limits, such as variations and uncertainties during the manufacturing process, temperature fluctuations, and ageing effects. As a result, either a broad security margin must be applied, which restricts the optimal utilization of DVFS, or the limits must be dynamically updated.

Several works propose implementations of this countermeasure. These solutions first subject the device to various OPPs to characterize their stability based on the supply voltage and frequency. Then, they prevent the device from operating with an unstable OPP using various approaches. In [51], a kernel module polls the voltage and frequency registers to prevent using OPPs beyond a fixed safety threshold. Although this module can be unloaded by an attacker who controls the rich OS, an attestation can be used to verify its integrity. However, no evidence is provided to indicate that this solution effectively prevents undervolting attacks.

In [19], a lightweight machine-learning model is trained based on the previously mentioned characterization. It predicts whether an OPP is safe to use or not. Dedicated coprocessors, one per CPU core, independent of both the CPU and the PMIC, run this model. A decision boundary controls the restrictiveness of the blacklist core, and it is updated when a fault occurs during runtime to account for the effects of temperature and aging. The behaviour of the blacklist core regarding this decision boundary is to be implemented by TEE and SoC designers. The authors measure the prediction latency to be 1.11 μ s, which is added as overhead to each frequency change request. One Blacklist Core consumes 10.5 mW at 250 MHz. This static overhead in the device's energy performance should be weighed against the benefits of this countermeasure compared to simply restricting the usable operating points to a vendor-defined discrete state, as in Intel processors which use the *Speed Shift* technology, for instance.

In [52], Juffinger *et al.* present a hardware-software co-design introducing a second set of OPP to the device. This supplementary set offers more aggressive energy savings compared to the base one, featuring lower supply voltages for the same operating frequencies while maintaining high performance. To prevent undervolting faults, the system switches to the base conservative OPP set when executing highly faultable instructions. Additionally, instructions that are both faultable and frequent are made safer by relaxing their critical path; for example, multiplications are granted one additional clock cycle. Although the primary objective of this work is to

enhance the device's energy efficiency safely, it also presents a promising avenue for mitigating DVFS fault attacks.

3) *Keep separate hardware regulators*: Another countermeasure is to split the regulators so that they are not shared between trusted and untrusted programs. If regulators were common to all cores, or if the victim and attacker's applications shared the same regulator, faults would impact not only the victim application but also the attacker's own program [32]. Another option is to use separate regulators, depending on whether a CPU core is in a secure or non-secure state [4].

Implementing such a solution poses several challenges. First, maintaining multiple physical regulators per core may incur significant costs. Second, at the software level, access to the regulators must be restricted based on the core and execution environment of the current program. This necessitates a comprehensive power management solution across different software layers in the trusted world, which could introduce performance overhead and enlarge the size of the TCB [4]. Reserving one or several CPU cores exclusively for trusted programs, equipped with dedicated hardware regulators, would simplify the implementation of this countermeasure, as suggested in [32]. However, this approach would essentially resemble using a TPM or a coprocessor. As demonstrated in section II-C, this contradicts the goals of TEEs, which strive to offer isolation while utilizing the same hardware resources for both trusted and untrusted programs. To the best of our knowledge, no published work has implemented this countermeasure.

4) *Harden trusted programs and hardware against faults*: Countermeasures outlined in the preceding paragraphs effectively prevent attackers from injecting faults into trusted programs, thereby thwarting all known DVFS fault attacks. However, in this paragraph, we delve into alternative approaches aimed at securing trusted programs against these attacks. These strategies involve modifying trusted programs themselves to render them resilient to faults. While these countermeasures do not preempt DVFS attacks, they either detect faults upon occurrence and rectify their effects or render faults impractical for exploitation by attackers. Although these countermeasures typically introduce more overhead than the aforementioned solutions, this overhead is confined to trusted programs, with no impact on the rest of the system. Another notable distinction from the above solutions is that these countermeasures assume that developers of trusted software bear the responsibility for safeguarding their programs from potential attackers. Consequently, they are only pertinent in cases where TEE vendors have not furnished lower-level mitigations against fault attacks from the outset.

Redundancy and error detection codes, such as parity checks, are commonly utilized to both detect and mitigate the effects of faults. This can be achieved through software means by duplicating instructions at compilation, manually implementing redundancy checks in the code software, or even duplicating the entire encryption or decryption process, although the latter incurs significant overheads [30]. Another approach is infection, wherein a completely erroneous cipher is produced in the event of a fault during encryption, rendering

the output cipher unusable for attackers. Tao et al. explore the potential use of these three countermeasures (parity codes, redundancy-based methods, ineffective computation) against DVFS fault attacks targeting AES encryption in [53]. They determine that the most cost-effective countermeasure, in terms of both performance and code size overheads, is temporal redundancy (*i.e.*, running the encryption process twice serially), with overheads of 34.18% and 12.04% in performance and code size, respectively. However, they do not empirically assess the robustness of this countermeasure against actual overclocking or undervolting attacks. In [49], Huang *et al.* propose to substitute the most faultable instructions with safer ones. Some instructions can't be replaced, and for some others the substitutes don't provide a satisfying protection against DVFS fault attacks, the fault rate being reduced by about half or less.

A countermeasure proposed in [48] detects undervolting fault attacks using a compiler extension. It involves inserting *trap* instructions into the victim code. As mentioned in Section III, undervolting Intel processors increases the likelihood of certain instructions being faulted, such as multiplications and vector operations. However, this countermeasure introduces significant overhead in terms of both execution time and code size of the protected program. For instance, in the tested scenarios, it resulted in a performance overhead of 148.4% and a code size overhead ranging from 50% to 150% to mitigate 99% of DVFS fault attacks. Additionally, this approach is tailored specifically for undervolting-based attacks on x86 Intel platforms and may not generalize well to other architectures.

Redundancy can also be implemented at the hardware level, such as duplicating the entire instruction stream, but this approach comes with significant cost and area overhead. Alternatively, hardware-based methods to defend against fault attacks can be explored, such as control-flow integrity enforcement [54]. Moreover, leveraging the RISC-V ISA opens up opportunities for hardware and cross-layer countermeasures that operate at both the compiler and hardware levels [55]–[57]. As of now, there have been no published attempts to utilize these methods to mitigate software-induced energy-based fault attacks.

B. Side-Channel Attacks Countermeasures

Unlike fault attacks, SCAs are passive and thus more challenging to detect and thwart. Because they exploit the same vectors as covert channel attacks, it's reasonable to assume that similar countermeasures could mitigate both types of attacks. Just as with fault attacks, some of these countermeasures aim to entirely block attackers from carrying out SCAs, while others concentrate on making the attacks harder to exploit by obscuring results or concealing sensitive information.

Firstly, let's describe countermeasures that effectively prevent attackers from exploiting the side channels outlined in Section III. To thwart attacks like *Platypus* [13], which derive information from direct readings of instantaneous power consumption or frequency, several solutions can make the side channel challenging for attackers to exploit. In-

tel's approach against *Platypus* involves scrambling software-accessible power traces when SGX is enabled [50]. Power traces sent directly to hardware components remain unaffected. The scrambling is achieved by randomizing the values sent to the software-accessible voltage MSRs. This practically makes this internal power side-channel unusable for the attacker, but it also induces a variation in the energy reporting of about 5-10%, which can potentially harm some energy-aware programs which need precise data on the energy consumption. However, this imprecision is to be put in perspective with the inherent approximation of the estimation-based RAPL energy reporting [58]. Another tactic is to reduce the granularity of software-accessible counters and embedded sensors to hinder energy-based SCAs. However, even with a low-resolution channel (*e.g.*, one measurement every 10 ms [12]), attackers may still infer sensitive information.

For the other category of energy-management-related SCAs, which employs frequency throttling as the side channel [5], [39]–[41], attackers can facilitate the attack by altering the power or temperature threshold at which throttling occurs [39]. This can be effectively mitigated using TEEs by restricting access to corresponding configuration registers or files to trusted programs. Such restriction compels attackers to increase the system workload to induce throttling, which is less practical. However, this comes in contradiction with one of the main reasons for which this throttling mechanism exists in the first place: power clamping, *i.e.*, allowing the user to define an energy budget over a given period of time [59].

Secondly, traditional algorithm-level countermeasures against power analysis (both physical and remote) can be employed to increase the difficulty of exploiting these attacks. These solutions encompass masking, threshold implementations, and key refreshing, which may be implemented in trusted programs to shield them against both types of attacks [39], [60].

C. Summary on existing countermeasures against internal energy-based attacks

As demonstrated in the preceding paragraphs, the focus on internal energy-based attacks has predominantly centred on securing processors against fault attacks. However, the solutions adopted by manufacturers — namely, restricting direct kernel control over OPP and relying on governor-based DVFS management — limit the optimal utilization of DVFS, resulting in energy inefficiency. Furthermore, the emergence of throttling-based attacks [5] underscores that governor-based DVFS also presents an exploitable side-channel for attackers. This approach fails to address the underlying cause of these attacks: the shared and accessible nature of energy management mechanisms by both the TEE and the RE, inherently constituting a side-channel. Nevertheless, the implementation of separate regulators for the two domains may prove costly and challenging to justify. Recent works proposing specific countermeasures against energy-based fault injection attacks [19], [48], [51] offer promising avenues for securing TEEs, albeit highlighting the substantial challenges in terms of overhead and implementation complexity. Additionally, we

posit that leveraging features of modern TEE designs, such as the exclusive assignment of hardware peripherals [18] or attestation, could enhance countermeasure effectiveness. Besides, this allows the TEE to stay the sole trusted actor in the system, thereby centralizing the TCB.

Meanwhile, while specific countermeasures against fault attacks proposed to date [19], [48] show promise, they await implementation in actual hardware TEE technologies. Lastly, to our knowledge, no published work has proposed countermeasures against energy-based software SCAs beyond hardening the algorithms under attack or restricting access to their interfaces, akin to fault attacks. However, the efficacy of the latter countermeasure may vary for frequency-based SCAs, as attackers can simply measure program execution time instead of directly accessing frequency registers [5].

V. CONCLUSION

In this article, we conducted a thorough literature review of a novel category of software-induced hardware attacks, focusing on the malicious exploitation of power management mechanisms. We also examined existing countermeasures aimed at mitigating these attacks and explored potential strategies for integrating them into TEEs. Our analysis underscores the considerable challenges inherent in safeguarding TEE implementations against energy-based attacks, highlighting this as a promising avenue for future research. Our key conclusions can be summarized as follows.

Firstly, internal energy-based attacks, including fault attacks, SCAs, and covert communications, pose a significant threat to TEE implementations. This evolving threat landscape demands attention as attackers continue to develop more sophisticated and potent attack vectors, such as frequency throttling. Despite the increasing prominence of these attacks, previous academic work on hardware TEE designs has largely overlooked them. Therefore, it is imperative that next-generation TEE technologies integrate robust countermeasures to address this evolving threat landscape.

Emerging countermeasures against internal energy-based fault attacks, as evidenced in recent literature [19], [48], offer promising avenues to secure TEEs against these threats without overly constraining their power management mechanisms. Nonetheless, the practical implementation and testing of these countermeasures, especially in next-generation RISC-V based TEE designs, require further evaluation. Additionally, the exploration of mitigation strategies for energy-management-based SCAs remains an open area for future research.

ACKNOWLEDGMENTS

This research is supported by the French Research Agency (ANR) under the CoPhyTEE JCJC project contract ANR-23-CE39-0003-01.

REFERENCES

[1] V. Costan, I. Lebedev, and S. Devadas, "Sanctum: Minimal hardware extensions for strong software isolation," in *25th USENIX Security Symposium (USENIX Security 16)*. Austin, TX: USENIX Association, Aug. 2016, pp. 857–874.

[2] D. Lee, D. Kohlbrenner, S. Shinde, K. Asanović, and D. Song, "Keystone: an open framework for architecting trusted execution environments," in *Proceedings of the Fifteenth European Conference on Computer Systems*, ser. EuroSys '20. New York, NY, USA: Association for Computing Machinery, 2020.

[3] D. Schrammel, M. Waser, L. Lamster, M. Unterguggenberger, and S. Mangard, "Spear-v: Secure and practical enclave architecture for risc-v," in *Proceedings of the 2023 ACM Asia Conference on Computer and Communications Security*, ser. ASIA CCS '23. New York, NY, USA: Association for Computing Machinery, 2023, p. 457–468.

[4] A. Tang, S. Sethumadhavan, and S. Stolfo, "CLKSCREW: Exposing the perils of Security-Oblivious energy management," in *26th USENIX Security Symposium (USENIX Security 17)*. Vancouver, BC: USENIX Association, Aug. 2017, pp. 1057–1074.

[5] Y. Wang, R. Paccagnella, E. T. He, H. Shacham, C. W. Fletcher, and D. Kohlbrenner, "Hertzbleed: Turning power Side-Channel attacks into remote timing attacks on x86," in *31st USENIX Security Symposium (USENIX Security 22)*. Boston, MA: USENIX Association, Aug. 2022, pp. 679–697.

[6] K. Murdock, D. Oswald, F. D. Garcia, J. Van Bulck, D. Gruss, and F. Piessens, "Plundervolt: Software-based fault injection attacks against intel sgx," in *Proceedings of the 41st IEEE Symposium on Security and Privacy (S&P'20)*, 2020.

[7] J. Haj-Yahya, L. Orosa, J. S. Kim, J. G. Luna, A. Yaglikci, M. Alser, I. Puddu, and O. Mutlu, "Ichannels: Exploiting current management mechanisms to create covert channels in modern processors," in *2021 ACM/IEEE 48th Annual International Symposium on Computer Architecture (ISCA)*. Los Alamitos, CA, USA: IEEE Computer Society, jun 2021, pp. 985–998.

[8] S. Pinto and N. Santos, "Demystifying arm trustzone: A comprehensive survey," *ACM Comput. Surv.*, vol. 51, no. 6, jan 2019.

[9] S. Fei, Z. Yan, W. Ding, and H. Xie, "Security vulnerabilities of sgx and countermeasures: A survey," *ACM Comput. Surv.*, vol. 54, no. 6, jul 2021.

[10] G. Dessouky, A.-R. Sadeghi, and E. Stapf, "Enclave computing on risc-v: A brighter future for security?" in *1st International Workshop on Secure RISC-V Architecture Design Exploration (SECRISC-V)*, April 2020.

[11] D. Gruss, C. Maurice, and S. Mangard, "Rowhammer.js: A Remote Software-Induced Fault Attack in JavaScript," in *Detection of Intrusions and Malware, and Vulnerability Assessment*, J. Caballero, U. Zurutuza, and R. J. Rodríguez, Eds. Cham: Springer International Publishing, 2016, pp. 300–321.

[12] D. R. Dipta and B. Gulmezoglu, "Df-sca: Dynamic frequency side channel attacks are practical," in *Proceedings of the 38th Annual Computer Security Applications Conference*, ser. ACSAC '22. New York, NY, USA: Association for Computing Machinery, 2022, p. 841–853.

[13] M. Lipp, A. Kogler, D. Oswald, M. Schwarz, C. Easdon, C. Canella, and D. Gruss, "Platypus: Software-based power side-channel attacks on x86," in *2021 IEEE Symposium on Security and Privacy (SP)*, 2021, pp. 355–371.

[14] E. M. Benhani and L. Bossuet, "Dvfs as a security failure of trustzone-enabled heterogeneous soc," in *2018 25th IEEE International Conference on Electronics, Circuits and Systems (ICECS)*, 2018, pp. 489–492.

[15] H. Mantel, J. Schickel, A. Weber, and F. Weber, "How secure is green it? the case of software-based energy side channels," in *Computer Security*, J. Lopez, J. Zhou, and M. Soriano, Eds. Cham: Springer International Publishing, 2018, pp. 218–239.

[16] ARM, "Power and Performance Management using Arm SCMI Specification," 2019.

[17] S. Weiser, M. Werner, F. Brasser, M. Malenko, S. Mangard, and A.-R. Sadeghi, "TIMBER-V: Tag-Isolated Memory Bringing Fine-grained Enclaves to RISC-V," in *Proceedings 2019 Network and Distributed System Security Symposium*. San Diego, CA: Internet Society, 2019.

[18] R. Bahmani, F. Brasser, G. Dessouky, P. Jauernig, M. Klimmek, A.-R. Sadeghi, and E. Stapf, "CURE: A security architecture with Customizable and resilient enclaves," in *30th USENIX Security Symposium (USENIX Security 21)*. USENIX Association, Aug. 2021, pp. 1073–1090.

[19] S. Zhang, A. Tang, Z. Jiang, S. Sethumadhavan, and M. Seok, "Blacklist core: Machine-learning based dynamic operating-performance-point blacklisting for mitigating power-management security attacks," in *Proceedings of the International Symposium on Low Power Electronics and Design*, ser. ISLPED '18. New York, NY, USA: Association for Computing Machinery, 2018.

[20] R. Schone, T. Ilsche, M. Bielert, M. Velten, M. Schmidl, and D. Hackenberg, "Energy efficiency aspects of the amd zen 2 architecture," in *2021*

- IEEE International Conference on Cluster Computing (CLUSTER)*. Los Alamitos, CA, USA: IEEE Computer Society, sep 2021, pp. 562–571.
- [21] M. Schweikhardt and M. Hahn, “DFS for mixed criticality real time scenarios on 11th generation intel core processors,” Mar. 2022.
- [22] P. Bose, A. Buyuktosunoglu, J. A. Darringer, M. S. Gupta, M. B. Healy, H. Jacobson, I. Nair, J. A. Rivers, J. Shin, A. Vega, and A. J. Weger, “Power management of multi-core chips: Challenges and pitfalls,” in *2012 Design, Automation & Test in Europe Conference & Exhibition (DATE)*, 2012, pp. 977–982.
- [23] Intel, “Intel® 64 and IA-32 Architectures Software Developer’s Manual. Vol. 3, part 15.4,” 2021.
- [24] K. Gomina, J.-B. Rigaud, P. Gendrier, P. Candelier, and A. Tria, “Power supply glitch attacks: Design and evaluation of detection circuits,” in *2014 IEEE International Symposium on Hardware-Oriented Security and Trust (HOST)*, 2014, pp. 136–141.
- [25] A. Shamel-Sendi, “Understanding linux kernel vulnerabilities,” *Journal of Computer Virology and Hacking Techniques*, vol. 17, 12 2021.
- [26] J. Osborn and D. Challenger, “Trusted platform module evolution,” *John Hopkins APL Technical Digest*, vol. 32, pp. 536–543, 09 2013.
- [27] M. Sabt, M. Achemlal, and A. Bouabdallah, “Trusted execution environment: What it is, and what it is not,” in *2015 IEEE TrustCom/BigDataSE/ISPA*, vol. 1, 2015, pp. 57–64.
- [28] J.-E. Ekberg, K. Kostianinen, and N. Asokan, “Trusted execution environments on mobile devices,” in *Proceedings of the 2013 ACM SIGSAC Conference on Computer & Communications Security*, ser. CCS ’13. New York, NY, USA: Association for Computing Machinery, 2013, p. 1497–1498.
- [29] L. Yan, Y. Guo, X. Chen, and H. Mei, “A study on power side channels on mobile devices,” in *Proceedings of the 7th Asia-Pacific Symposium on Internetware*, ser. Internetware ’15, 2015, p. 30–38.
- [30] A. M. Shuvo, T. Zhang, F. Farahmandi, and M. Tehranipoor, “A Comprehensive Survey on Non-Invasive Fault Injection Attacks,” *Sensors*, 2022.
- [31] D. G. Mahmoud, S. Hussein, V. Lenders, and M. Stojilović, “FPGA-to-CPU undervolting attacks,” in *2022 Design, Automation & Test in Europe Conference & Exhibition (DATE)*, 2022, pp. 999–1004.
- [32] P. Qiu, D. Wang, Y. Lyu, and G. Qu, “Voltjockey: Breaching trustzone by software-controlled voltage manipulation over multi-core frequencies,” in *Proceedings of the 2019 ACM SIGSAC Conference on Computer and Communications Security*, ser. CCS ’19. New York, NY, USA: Association for Computing Machinery, 2019, p. 195–209.
- [33] —, “Voltjockey: Breaking sgx by software-controlled voltage-induced hardware faults,” in *2019 Asian Hardware Oriented Security and Trust Symposium (AsianHOST)*, 2019, pp. 1–6.
- [34] Z. Kenjar, T. Frassetto, D. Gens, M. Franz, and A.-R. Sadeghi, “VOLTpwn: Attacking x86 processor integrity from software,” in *29th USENIX Security Symposium (USENIX Security 20)*. USENIX Association, Aug. 2020, pp. 1445–1461.
- [35] S. Noubir, M. Mendez Real, and S. Pillement, “Towards malicious exploitation of energy management mechanisms,” in *2020 Design, Automation & Test in Europe Conference & Exhibition (DATE)*, 2020, pp. 1043–1048.
- [36] A. Rabich, “Software-based Undervolting Faults in AMD Zen Processors,” Ph.D. dissertation, Aug. 2020.
- [37] Y. Qin and C. Yue, “Website fingerprinting by power estimation based side-channel attacks on android 7,” in *2018 17th IEEE International Conference On Trust, Security And Privacy In Computing And Communications/ 12th IEEE International Conference On Big Data Science And Engineering (TrustCom/BigDataSE)*, 2018, pp. 1030–1039.
- [38] Y. Michalevsky, A. Schulman, G. A. Veerapandian, D. Boneh, and G. Nakibly, “PowerSpy: Location tracking using mobile device power analysis,” in *24th USENIX Security Symposium (USENIX Security 15)*. Washington, D.C.: USENIX Association, Aug. 2015, pp. 785–800.
- [39] C. Liu, A. Chakraborty, N. Chawla, and N. Roggel, “Frequency throttling side-channel attack,” in *Proceedings of the 2022 ACM SIGSAC Conference on Computer and Communications Security*, ser. CCS ’22. New York, NY, USA: Association for Computing Machinery, 2022, p. 1977–1991.
- [40] H. Taneja, J. Kim, J. J. Xu, S. Van Schaik, D. Genkin, and Y. Yarom, “Hot pixels: frequency, power, and temperature attacks on gpus and arm socs,” in *Proceedings of the 32nd USENIX Conference on Security Symposium*, ser. SEC ’23. USA: USENIX Association, 2023.
- [41] Y. Wang, R. Paccagnella, A. Wandke, Z. Gang, G. Garrett-Grossman, C. W. Fletcher, D. Kohlbrenner, and H. Shacham, “Dvfs frequently leaks secrets: Hertzbleed attacks beyond sike, cryptography, and cpu-only data,” in *2023 IEEE Symposium on Security and Privacy (SP)*, 2023, pp. 2306–2320.
- [42] A. Kogler, J. Juffinger, L. Giner, L. Gerlach, M. Schwarzl, M. Schwarz, D. Gruss, and S. Mangard, “Collide+Power: Leaking Inaccessible Data with Software-based Power Side Channels,” in *USENIX Security*, 2023.
- [43] M. Yue, W. H. Robinson, L. Watkins, and C. Corbett, “Constructing timing-based covert channels in mobile networks by adjusting cpu frequency,” in *Proceedings of the Third Workshop on Hardware and Architectural Support for Security and Privacy*, ser. HASP ’14. New York, NY, USA: Association for Computing Machinery, 2014.
- [44] M. Alagappan, J. Rajendran, M. Doroslovački, and G. Venkataramani, “DFS covert channels on multi-core platforms,” in *2017 IFIP/IEEE International Conference on Very Large Scale Integration (VLSI-SoC)*, 2017, pp. 1–6.
- [45] S. K. Khatamifard, L. Wang, A. Das, S. Kose, and U. R. Karpuzcu, “Powert channels: A novel class of covert communication exploiting power management vulnerabilities,” in *2019 IEEE International Symposium on High Performance Computer Architecture (HPCA)*, 2019, pp. 291–303.
- [46] P. Miedl, X. He, M. Meyer, D. B. Bartolini, and L. Thiele, “Frequency scaling as a security threat on multicore systems,” *IEEE Transactions on Computer-Aided Design of Integrated Circuits and Systems*, vol. 37, no. 11, pp. 2497–2508, 2018.
- [47] M. Kalmbach, M. Gottschlag, T. Schmidt, and F. Bellosa, “TurboCC: A practical frequency-based covert channel with intel turbo boost,” 2020.
- [48] A. Kogler, D. Gruss, and M. Schwarz, “Minefield: A software-only protection for SGX enclaves against DVFS attacks,” in *31st USENIX Security Symposium (USENIX Security 22)*. Boston, MA: USENIX Association, Aug. 2022, pp. 4147–4164.
- [49] J. Huang, J. Ye, X. Ye, D. Wang, D. Fan, H. Li, X. Li, and Z. Zhang, “Instruction vulnerability test and code optimization against dvfs attack,” in *2019 IEEE International Test Conference in Asia (ITC-Asia)*, 2019, pp. 49–54.
- [50] Intel, “Running Average Power Limit Energy Reporting CVE-2020-8694, CVE-2020-8695,” Feb. 2022.
- [51] N. Mishra, R. A. Mool, and A. Chakraborty, “Plug Your Volt: Protecting Intel Processors against Dynamic Voltage Frequency Scaling based Fault Attacks,” 2023.
- [52] J. Juffinger, S. Kalinin, D. Gruss, and F. Mueller, “Suit: Secure undervolting with instruction traps,” in *Proceedings of the 29th ACM International Conference on Architectural Support for Programming Languages and Operating Systems, Volume 2*, ser. ASPLOS ’24. New York, NY, USA: Association for Computing Machinery, 2024, p. 1128–1145.
- [53] Z. Tao, R. Sun, and J. Dong, “Software countermeasures against DVFS fault attack for AES,” in *2023 10th International Conference on Dependable Systems and Their Applications (DSA)*, 2023, pp. 575–582.
- [54] M. Werner, R. Schilling, T. Unterluggauer, and S. Mangard, “Protecting risc-v processors against physical attacks,” in *2019 Design, Automation & Test in Europe Conference & Exhibition (DATE)*, 2019, pp. 1136–1141.
- [55] J. Laurent, V. Beroulle, C. Deleuze, F. Pebay-Peyroula, and A. Papadimitriou, “Cross-layer analysis of software fault models and countermeasures against hardware fault attacks in a risc-v processor,” *Microprocessors and Microsystems*, vol. 71, p. 102862, 2019.
- [56] S. Michelland, C. Deleuze, and L. Gonnord, “From low-level fault modeling (of a pipeline attack) to a proven hardening scheme,” in *Compiler Construction (CC’24)*, Edinburgh (Scotland), United Kingdom, Mar. 2024.
- [57] B. Yuce, N. F. Ghalaty, C. Deshpande, C. Patrick, L. Nazhandali, and P. Schaumont, “FAME: Fault-attack Aware Microprocessor Extensions for Hardware Fault Detection and Software Fault Response,” in *Proceedings of the Hardware and Architectural Support for Security and Privacy 2016*. Seoul Republic of Korea: ACM, Jun. 2016, pp. 1–8.
- [58] D. Hackenberg, T. Ilsche, R. Schöne, D. Molka, M. Schmidt, and W. E. Nagel, “Power measurement techniques on standard compute nodes: A quantitative comparison,” in *2013 IEEE International Symposium on Performance Analysis of Systems and Software (ISPASS)*, Apr. 2013, pp. 194–204.
- [59] B. Rountree, D. H. Ahn, B. R. de Supinski, D. K. Lowenthal, and M. Schulz, “Beyond DVFS: A First Look at Performance under a Hardware-Enforced Power Bound,” in *2012 IEEE 26th International Parallel and Distributed Processing Symposium Workshops & PhD Forum*, May 2012, pp. 947–953.
- [60] E. De Mulder, S. Gummalla, and M. Hutter, “Protecting RISC-V against Side-Channel Attacks,” in *Proceedings of the 56th Annual Design Automation Conference 2019*. Las Vegas NV USA: ACM, Jun. 2019, pp. 1–4.